

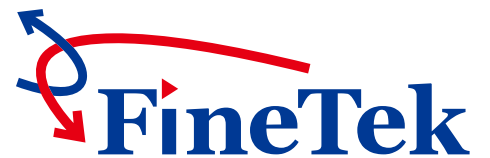

EPD Electromagnetic Flow Meter



www.fine-tek.com



FLOW MEASUREMENT FIELD

FineTek is the only inspection institution that owns a Class 2 flow test laboratory in Taiwan. With the most professional R&D and Design Team, it can design and develop high-accuracy electromagnetic flow meters. Moreover, it conducts calibration in Class 1 Flow Laboratory of the National Measurement Laboratory (ITRI Measurement Center), so as to guarantee the flow accuracy on the measurement field.

FineTek's flow laboratory has received certification from the Taiwan Accreditation Foundation and conforms to the regulations of international organizations such as ILAC and APALC. It has the complete ability of uncertainty testing and rating for flow test.



Flow inspection lab with TAF certification ■

Take weighing and parent metering as the foundation for measurement calibration ■

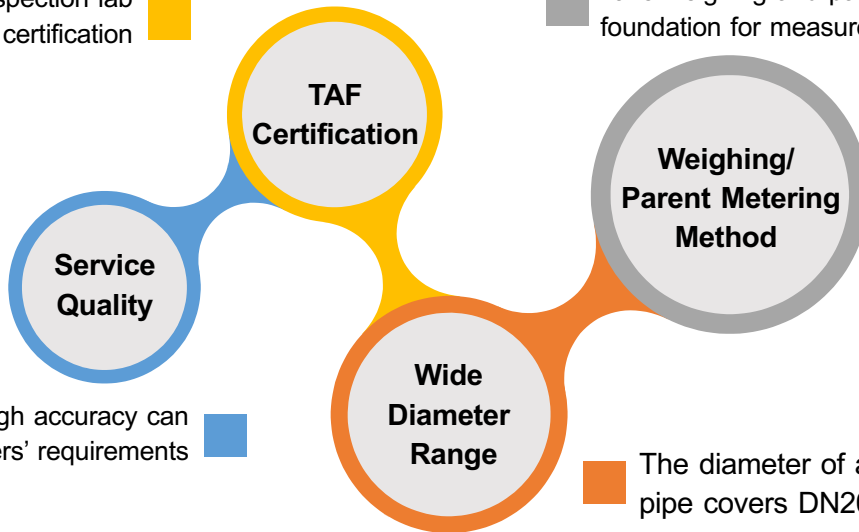

High quality and high accuracy can meet the customers' requirements ■

The diameter of applicable pipe covers DN20~ DN300 ■

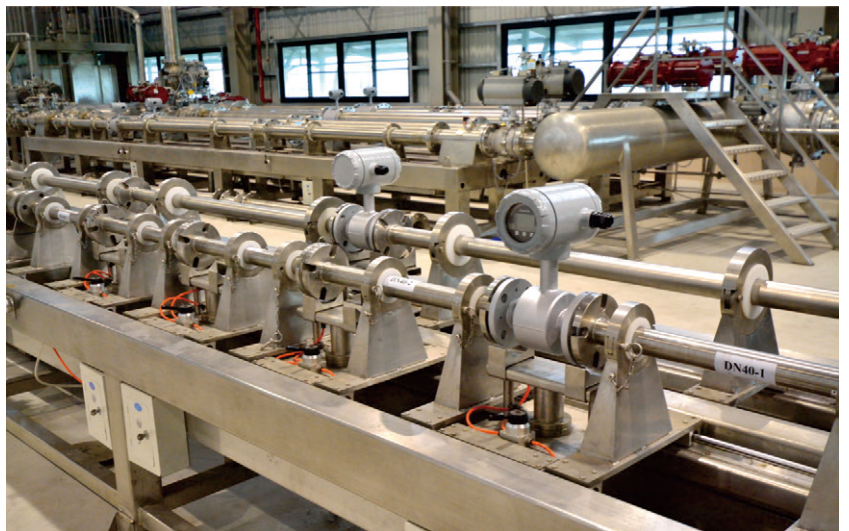
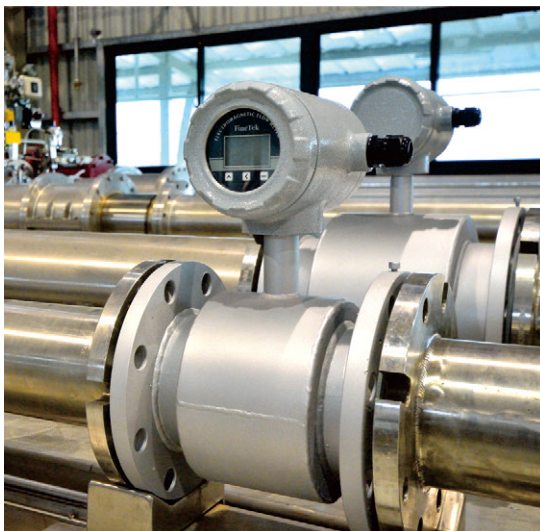

FLOW MEASUREMENT FIELD



PUMP equipment
(The maximum horsepower is 1100KW per unit)



Weighing equipment



Control room & Graphical HMI



Piping system I
(Max capacity for four meters calibration simultaneously in above system.)



Piping system II
(Maximum diameter is 300mm)

1. 測試項目 (Testing Item): 流量試驗
2. 測試日期 (Testing Date): 2016/09/08
3. 測試地點 (Testing Place): 宜鼎
4. 測試結果 (Result):
環境溫度 (Environmental Temperature): 25.00
相對濕度 (Relative Humidity): 65.00%

GE-16041175

電子秤編號	測試流量 (kg/h)	流速 (m/s)	口径 (mm)	受測件量測值 (kg)	流計分析		
					相對偏差 (%)	相對誤差 (%)	滿意度
3000 kg (8519902027)	254.47	0.98	300	0.825	0.01%	0.01%	2.08
				0.205	0.01%	0.01%	
				0.215	0.01%	0.01%	
3000 kg (8519902027)	127.24	0.50	300	1.000	0.00%	0.00%	2.08
				0.850	0.01%	0.01%	
				1.000	0.00%	0.00%	
3000 kg (8519902027)	76.34	0.31	300	0.67800	0.0011	0.0011	2.08
				0.67800	0.0011	0.0011	
				0.67800	0.0011	0.0011	

The exclusive report
(Each flow meter has its own calibration report)

ELECTROMAGNETIC FLOW METER

EPD electromagnetic flow meter is a high-accuracy flow meter manufactured based on the latest international technology. It is widely applied in papermaking, chemical industry, metallurgical industry, drainage, waste water treatment, liquid high-pressure metering, medical care, food, and environmental protection industries. It is used to measure the non-magnetic liquid and plasma in the enclosed pipe.

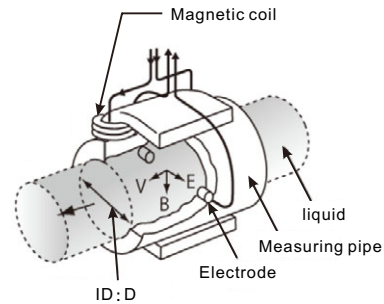
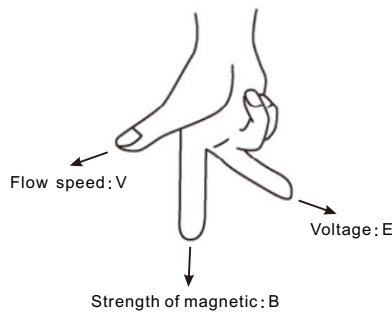

WORKING PRINCIPLE

The working principle of the electromagnetic flow meter is based on the Faraday law of electromagnetic induction. When the conducting liquid flows in the orthogonal direction of the magnetic line direction, it will cut the magnetic lines and generate induced voltage, which shows linear relationship with the flowing speed. Thus, the fluidic volume flow can be calculated.

EPD electromagnetic flow meter is mainly composed of the sensor and transmitter. The measuring tube of the sensor is equipped with the excitation coils upward and downward. The transmitter supplies the excitation current, which generates the magnetic field which goes through the measuring tube once it is powered on. A pair of induction electrodes installed on the inner side of the measuring tube comes in contact with the liquid to guide the induced voltage to the sensor.

APPLICATIONS

- Waste water treatment
- Tapped water purification
- Sewerage
- Sea water desalination module
- Dyeing machines
- Solar energy and PCB wet processing
- Food manufacturing
- Pharmaceutical machines

FEATURES

Low impact on environmental matter

- The measurement results are not affected by the change in liquid density, viscosity, temperature, pressure and conductivity.
- It can be widely applied in the conducting liquids that may contain fiber, solid granules and suspended matters.
- Enclosure protection rating: IP67/NEMA 4X

Wide measurement range & high efficiency

- The wide measurement turndown ratio can be reach 1:100, which can be set randomly and achieve high accuracy for small flow measurement.
- Highly-integrated backlit display of two rows, dual isolation, parameter setting, menu-type operation, memory function, reliable programming, password lock and access, small signal elimination, non-linear correction and two-way measurement.
- Various outputs: Current output 4~20mA, frequency output 2~8KHz and RS485 communication.

Multiple self-diagnosis function

- Power-saving and low fault rate: The measuring tube is without baffle and movable parts, so it won't cause pressure loss and jam.
- Smart self-detection and self-diagnosis function, as well as various alarms

The low installation cost

- It is easy-to-install with low requirements for the straight tube section (Front 5D and rear 2D)
- 2-wire analog output

SPECIFICATION

Item	EPD30 Standard type	EPD34 Remote type
Display	LCM 128*64 pixel backlit type	
Buttons	Tri-button operation	
Communication interface	RS-485 (Modbus) (Optional support for ZigBee Pro wireless transmission)	
Accuracy	±0.5% of reading@1m/s(0.2% optional)	
Medium temperature	-20 ~ 120 °C	
Ambient temperature	-40 ~ 70 °C ¹	
Fluidic conductivity	> 5 uS/cm	
Measuring scope	0.1m/s ~ 10m/s	
Current output accuracy	0.1% of Pulse Output Accuracy Temperature coefficient (100ppm/°C)	
Operating pressure	10Kg/cm ²	
Current output mode	Proactive	
Analog output	4 ~ 20mA	
Maximum load of current output	< 700Ω	
Alarming current	3.6mA or 22 mA	
Frequency output scope	2 ~ 8 Hz	
Pulse width	Automatic (pulse width 50%)	
Pulse mode	NPN transistor output 32vdc/200mA	
Time constant	0.1~20 s	0~100 s
Control output (DO)	NPN transistor output 32vdc/200mA ;2-CH	
Control input (DI)	Dry contact ON< 200Ω ; 1,000Ω< OFF ; 1-CH	
Baud rate	1200 ~ 38400 bps	1200 ~ 57600 bps
Protection rating	IP67 / NEMA 4X	
Enclosure material	Aluminum alloy	
Input power	AC 100~240 Vac	
Power consumption	< 10W	
Wire inlet specification	M20 x 1.5*2 Female	
Excitation mode	Pulse DC	
Vibration regulation	IEC 60068-2-3	
EMC regulation	IEC/EN 61326-1 Class A table2	

¹ It can't display when LCM is lower than -20°C.

MATERIAL SELECTION

✧Electrode material

Electrode material	Anti-corrosion property
Stainless steel (316L)	It is applied in water, sewage and organic and non-organic corrosive medium.
Hastelloy alloy	It is resistant to the corrosion of the medium mixture of oxidizing acid such as Nitric acid, mixed acid or Sulfuric acid. Moreover, it is resistant to the corrosion of the oxidizing salt such as Fe^{2+} 、 Cu^{2+} or other substances containing oxidants such as the salt solution of hypochlorous acid above the ambient temperature and sea water.
Titanium	It is resistant to the corrosion of sea water, various oxides, salt solution of hypochlorous acid, oxidating acid (including fuming Nitric acid) and organic acid and alkane. It is not resistant to the corrosion of pure reducing acid (such as Sulfuric acid and Hydrochloric acid). However, the anti-corrosion property will be greatly degraded if the acid contains some oxidants.
Tantalum	It has excellent corrosion resistance. Its characteristic is similar to glass. In addition to hydrofluoric acid , nitric acid , alkali, it could resist almost all chemical medium (including boiling hydrochloric acid, nitric acid and sulfuric acid below 175°C). It could not resist corrosion in alkali.

✧Lining material

Lining material	Main properties	Application scope
PTFE	<ol style="list-style-type: none"> 1. Stable chemical properties, resistant to various acid, alkane, and salt solutions and various organic solvents. It is not tolerant to the corrosion of ClF_3, high-temperature OF_3 and high-speed liquid oxygen and ozone. 2. The anti-abrasion property is average. 	<ol style="list-style-type: none"> 1. -20~120°C 2. Strong corrosive medium such as concentrated acid and alkane.
NBR	<ol style="list-style-type: none"> 1. Excellent flexibility, highly tearing force capability, good wear resistance 2. It is resistant to low concentrations of acid, alkali, salt solution;It is not tolerant the corrosion of oxidizing mediums. 	<ol style="list-style-type: none"> 1. < 80°C 2. Neutral-strong wearing mineral pulp, coal slurry and mud slurry
Neoprene	<ol style="list-style-type: none"> 1. Neutral wearing capability 2. It is resistant to low concentrations of acid, alkali, acid corrosion. 	<ol style="list-style-type: none"> 1. < 80°C 2. Water, Industrial water , Seawater

APPEARANCE AND DIMENSION AND FLANGE CONNECTION DIMENSION STANDARD TYPE

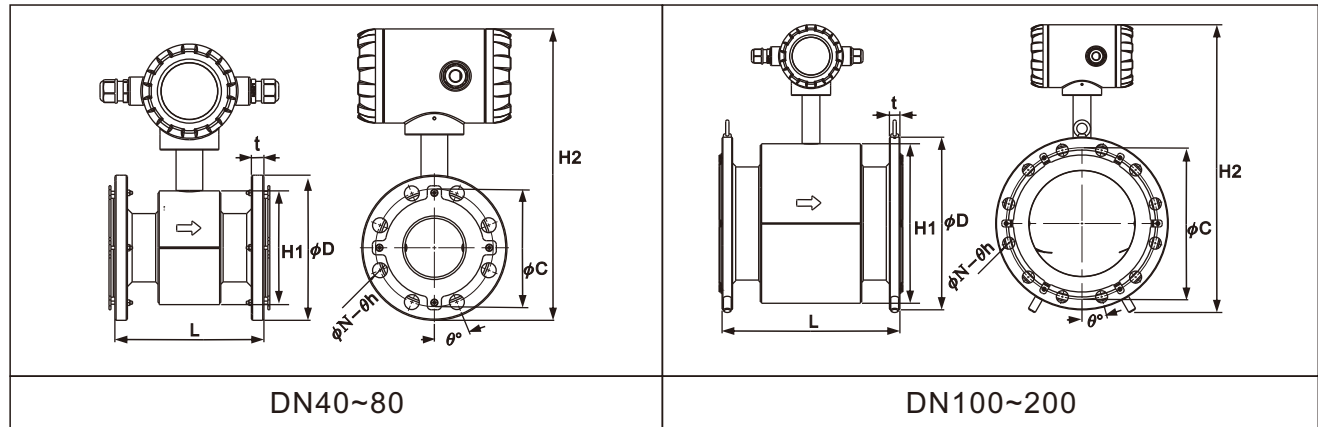

Connection specification		JIS 10K									
Nominal diameter(mm)		40	50	65	80	100	125	150	200	250	300
Lining material		PTFE									
Length	L	200	200	200	200	250	250	300	350	400	500
External diameter	ϕD	140	155	175	185	210	250	280	330	400	445
PCD	ϕC	105	120	140	150	175	210	240	290	355	400
Flange thickness	t	14	14	16	16	16	20	22	22	24	24
Inclined angle of screw hole	θ°	45	45	45	22.5	22.5	22.5	22.5	15	15	11.25
Diameter of screw hole	θh	19	19	19	19	19	19	23	23	25	25
Quantity of screw holes	N	4	4	4	8	8	8	8	12	12	16
Height of sensor casing	H1	125	125	145	145	195	195	270	305	365	406
Total height	H2	329	336	356	361	398.5	418.5	481	520	586	630
Weight (kg)		6.8	7.68	8.98	9.87	12.9	17.5	23.51	33.23	54.03	69.55

Connection specification		JIS 20K									
Nominal diameter(mm)		40	50	65	80	100	125	150	200	250	300
Lining material		PTFE									
Length	L	200	200	200	200	250	250	300	350	400	500
External diameter	ϕD	140	155	175	200	225	270	305	350	430	480
PCD	ϕC	105	120	140	160	185	225	260	305	380	430
Flange thickness	t	18	18	20	22	24	26	28	30	34	36
Inclined angle of screw hole	θ°	45	22.5	22.5	22.5	22.5	22.5	15	15	15	11.25
Diameter of screw hole	θh	19	19	23	23	23	25	25	25	27	27
Quantity of screw holes	N	4	8	8	8	8	8	12	12	12	16
Height of sensor casing	H1	125	125	145	145	195	195	270	305	365	406
Total height	H2	328.5	336	356	368.5	406	428.5	492	528	547	594
Weight (kg)		7.08	7.72	8.98	12.25	16.42	23.56	31.03	43.37	74.23	94.15

Remarks: For DN40~DN80, the lining protective ring is 2mm, so the total length of the flow meter shall be increased by 4mm. For DN100~DN200, the lining protective ring is 0.5mm, so the total length of the flow meter shall be increased by 1mm; total height (H2) tolerance is ± 2 mm

APPEARANCE AND DIMENSION AND FLANGE CONNECTION DIMENSION STANDARD TYPE

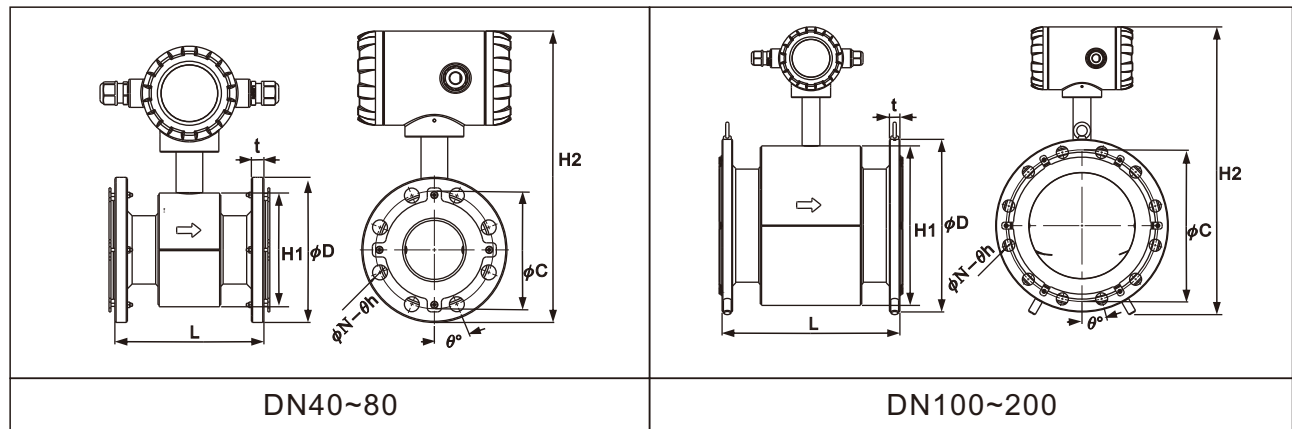

Connection specification		ANSI 150Lbs									
Nominal diameter(mm)		40	50	65	80	100	125	150	200	250	300
Lining material		PTFE									
Length	L	200	200	200	200	250	250	300	350	400	500
External diameter	ϕD	127	152	178	190	229	254	279.4	342.9	406.4	482.6
PCD	ϕC	98.4	120.6	139.7	152.4	190.5	215.9	241.3	298.4	361.9	431.8
Flange thickness	t	15.9	17.4	20.6	22.2	22.2	22.2	23.8	27	28.6	30.2
Inclined angle of screw hole	θ°	45	45	45	45	22.5	22.5	22.5	22.5	15	15
Diameter of screw hole	θh	15.9	19	19	19	19	22.2	22.2	22.2	25.4	25.4
Quantity of screw holes	N	4	4	4	4	8	8	8	8	12	12
Height of sensor casing	H1	125	125	145	145	195	195	265	305	365	406
Total height	H2	322	335	358	364	408	421	478	525	589	647
Weight (kg)		6.48	8.32	10.78	12.25	17.82	20.96	27.03	44.17	67.23	99.55

Connection specification		ANSI 300Lbs									
Nominal diameter(mm)		40	50	65	80	100	125	150	200	250	300
Lining material		PTFE									
Length	L	200	200	200	200	250	250	300	350	400	500
External diameter	ϕD	156	165	190	210	254	279	317.5	381	444.5	520.7
PCD	ϕC	114.3	127	149.2	168.3	200	235	269.9	330.2	387.35	450.9
Flange thickness	t	19	20.6	23.8	27	30.2	33.3	34.9	39.7	46	49.2
Inclined angle of screw hole	θ°	45	22.5	22.5	22.5	22.5	22.5	15	15	11.3	11.3
Diameter of screw hole	θh	22.2	19	22.2	22.2	22.2	22.2	22.2	25.4	28.6	31.8
Quantity of screw holes	N	4	8	8	8	8	8	12	12	16	16
Height of sensor casing	H1	125	125	145	145	195	195	265	305	365	406
Total height	H2	337	341	364	374	421	433	495	542	606	664
Weight (kg)		9.8	10.32	12.78	16.45	26.62	32.96	43.83	69.17	100.43	146.6

Remarks: For DN40~DN80, the lining protective ring is 2mm, so the total length of the flow meter shall be increased by 4mm. For DN100~DN200, the lining protective ring is 0.5mm, so the total length of the flow meter shall be increased by 1mm; total height (H2) tolerance is ± 2 mm

APPEARANCE AND DIMENSION AND FLANGE CONNECTION DIMENSION STANDARD TYPE

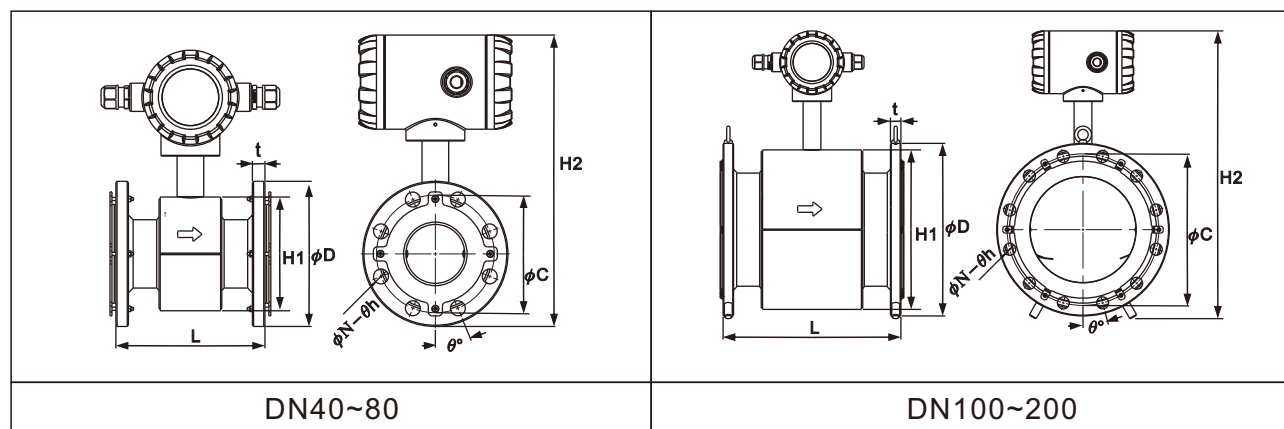

Connection specification	DIN PN40				DIN PN16						
Nominal diameter(mm)	40	50	65	80	65	80	100	125	150	200	
Lining material	PTFE										
Length	L	200	200	200	200	200	200	250	250	300	350
External diameter	ϕD	150	165	185	200	185	200	220	250	285	340
PCD	ϕC	110	125	145	160	145	160	180	210	240	295
Flange thickness	t	18	20	22	24	18	20	20	22	22	24
Inclined angle of screw hole	θ°	45	45	22.5	22.5	45	22.5	22.5	22.5	22.5	15
Diameter of screw hole	θh	18	18	18	18	18	18	18	18	22	22
Quantity of screw holes	N	4	4	8	8	4	8	8	8	8	12
Height of sensor casing	H1	125	125	145	145	145	145	195	195	265	305
Total height	H2	334	341	361	369	361	369	404	419	484	524
Weight (kg)		7.08	7.72	8.98	12.25	8.58	11.65	15.62	20.96	28.23	39.97

Connection specification	DIN PN10			
Nominal diameter(mm)	200	250	300	
Lining material	PTFE			
Length	L	350	400	500
External diameter	ϕD	340	395	445
PCD	ϕC	295	350	400
Flange thickness	t	24	26	26
Inclined angle of screw hole	θ°	22.5	15	15
Diameter of screw hole	θh	22	22	22
Quantity of screw holes	N	8	12	12
Height of sensor casing	H1	305	365	406
Total height	H2	524	582	651
Weight (kg)		33.23	54.03	69.55

Remarks: For DN40~DN80, the lining protective ring is 2mm, so the total length of the flow meter shall be increased by 4mm. For DN100~DN200, the lining protective ring is 0.5mm, so the total length of the flow meter shall be increased by 1mm; total height (H2) tolerance is ± 2 mm

APPEARANCE AND DIMENSION AND FLANGE CONNECTION DIMENSION REMOTE TYPE

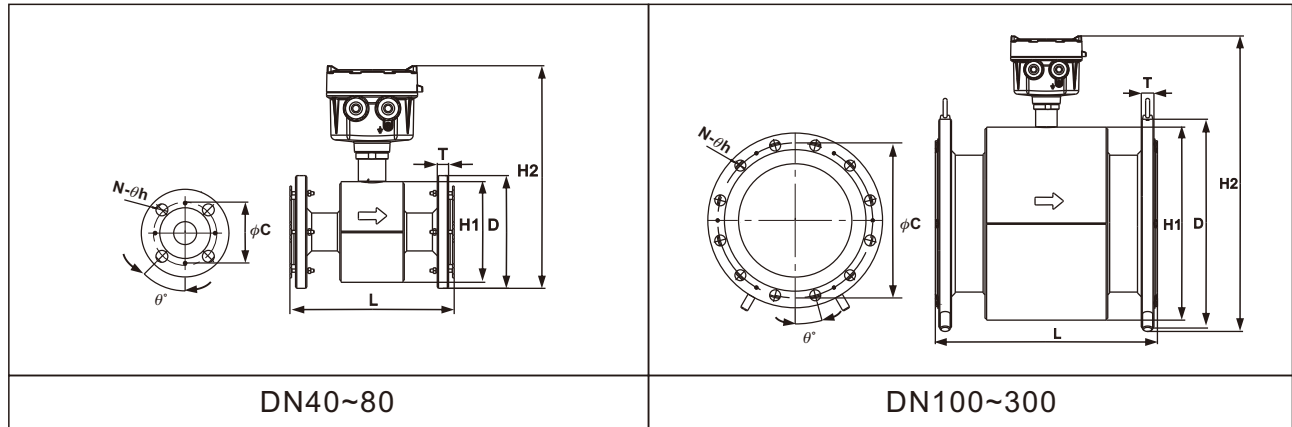

Connection specification		JIS 10K									
Nominal diameter(mm)		40	50	65	80	100	125	150	200	250	300
Lining material		PTFE									
Length	L	200	200	200	200	250	250	300	350	400	500
External diameter	ϕD	140	155	175	185	210	250	280	330	400	445
PCD	ϕC	105	120	140	150	175	210	240	290	355	400
Flange thickness	t	14	14	16	16	16	20	22	22	24	24
Inclined angle of screw hole	θ°	45	45	45	22.5	22.5	22.5	22.5	15	15	11.25
Diameter of screw hole	θh	19	19	19	19	19	19	23	23	25	25
Quantity of screw holes	N	4	4	4	8	8	8	8	12	12	16
Height of sensor casing	H1	125	125	145	145	195	195	270	305	365	406
Total height	H2	276.4	283.9	303.9	308.9	346.4	366.4	429	468	534	578
Weight (kg)*2	-	5.25	6.13	7.43	8.32	11.35	15.95	21.96	31.68	52.48	68.00

Connection specification		JIS 20K									
Nominal diameter(mm)		40	50	65	80	100	125	150	200	250	300
Lining material		PTFE									
Length	L	200	200	200	200	250	250	300	350	400	500
External diameter	ϕD	140	155	175	200	225	270	305	350	430	480
PCD	ϕC	105	120	140	160	185	225	260	305	380	430
Flange thickness	t	18	18	20	22	24	26	28	30	34	36
Inclined angle of screw hole	θ°	45	22.5	22.5	22.5	22.5	22.5	15	15	15	11.25
Diameter of screw hole	θh	19	19	23	23	23	25	25	25	27	27
Quantity of screw holes	N	4	8	8	8	8	8	12	12	12	16
Height of sensor casing	H1	125	125	145	145	195	195	270	305	365	406
Total height	H2	276.4	283.9	303.9	316.4	353.9	376.4	440	476	547	594
Weight (kg)*2	-	5.53	6.17	7.43	10.7	14.87	22.01	29.48	41.82	72.68	92.60

*1: The tolerance of total height is 3~5mm

*2: To shows the weight of sensor only. Not include the weight of transmitter 2.06kg

Note 1 : N40~DN80, the lining protection rings 2mm. The total flange-to-flange length of the flow meter needs to add 4mm

Note 2 : DN100~DN300, the lining protection rings 0.5mm. The total flange-to-flange length of the flow meter needs to add 1mm

APPEARANCE AND DIMENSION AND FLANGE CONNECTION DIMENSION REMOTE TYPE

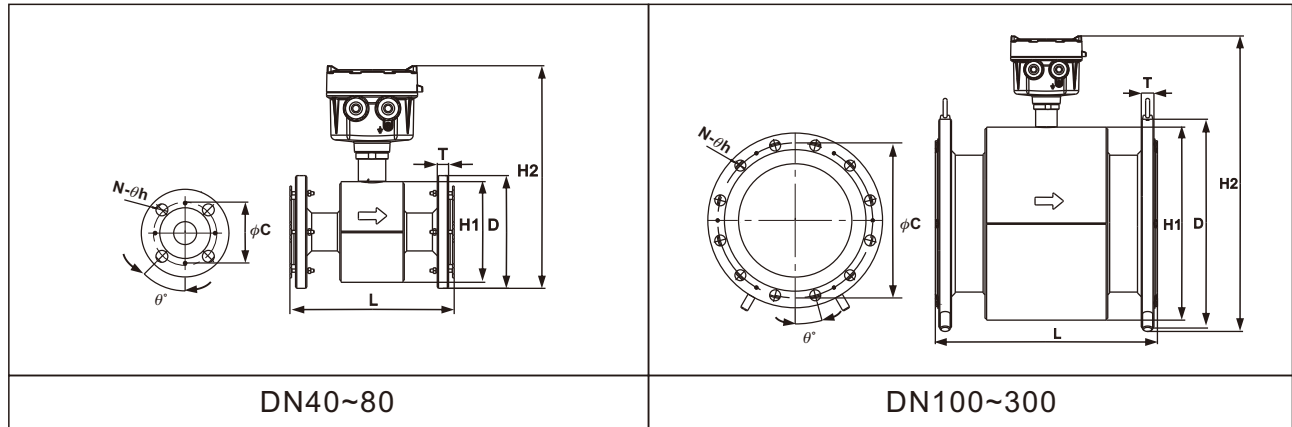

Connection specification		ANSI 150 Lbs									
Nominal diameter(mm)		40	50	65	80	100	125	150	200	250	300
Lining material		PTFE									
Length	L	200	200	200	200	250	250	300	350	400	500
External diameter	ϕD	127	152	178	190	229	254	279.4	342.9	406.4	482.6
PCD	ϕC	98.4	120.6	139.7	152.4	190.5	215.9	241.3	298.4	361.9	431.8
Flange thickness	t	15.9	17.4	20.6	22.2	22.2	22.2	23.8	27	28.6	30.2
Inclined angle of screw hole	θ°	45	45	45	45	22.5	22.5	22.5	22.5	15	15
Diameter of screw hole	θh	15.9	19	19	19	19	22.2	22.2	22.2	25.4	25.4
Quantity of screw holes	N	4	4	4	4	8	8	8	8	12	12
Height of sensor casing	H1	125	125	145	145	195	195	265	305	365	406
Total height	H2	322	335	358	364	408	421	478	525	589	647
Weight (kg)*2	-	4.93	6.77	9.23	10.7	16.27	19.41	25.48	42.62	65.68	98

Connection specification		ANSI 300 Lbs									
Nominal diameter(mm)		40	50	65	80	100	125	150	200	250	300
Lining material		PTFE									
Length	L	200	200	200	200	250	250	300	350	400	500
External diameter	ϕD	156	165	190	210	254	279	317.5	381	444.5	520.7
PCD	ϕC	114.3	127	149.2	168.3	200	235	269.9	330.2	387.35	450.85
Flange thickness	t	19	20.6	23.8	27	30.2	33.3	34.9	39.7	46	49.2
Inclined angle of screw hole	θ°	45	22.5	22.5	22.5	22.5	22.5	15	15	11.3	11.3
Diameter of screw hole	θh	22.2	19	22.2	22.2	22.2	22.2	22.2	25.4	28.6	31.8
Quantity of screw holes	N	4	8	8	8	8	8	12	12	16	16
Height of sensor casing	H1	125	125	145	145	195	195	265	305	365	406
Total height	H2	337	341	364	374	421	433	495	542	606	664
Weight (kg)*2	-	9.08	10.32	12.78	16.45	26.62	32.96	42.28	67.62	98.88	145

*1: The tolerance of total height is 3~5mm

*2: To shows the weight of sensor only. Not include the weight of transmitter 2.06kg

Note 1 : N40~DN80, the lining protection rings 2mm. The total flange-to-flange length of the flow meter needs to add 4mm

Note 2 : DN100~DN300, the lining protection rings 0.5mm. The total flange-to-flange length of the flow meter needs to add 1mm

APPEARANCE AND DIMENSION AND FLANGE CONNECTION DIMENSION REMOTE TYPE

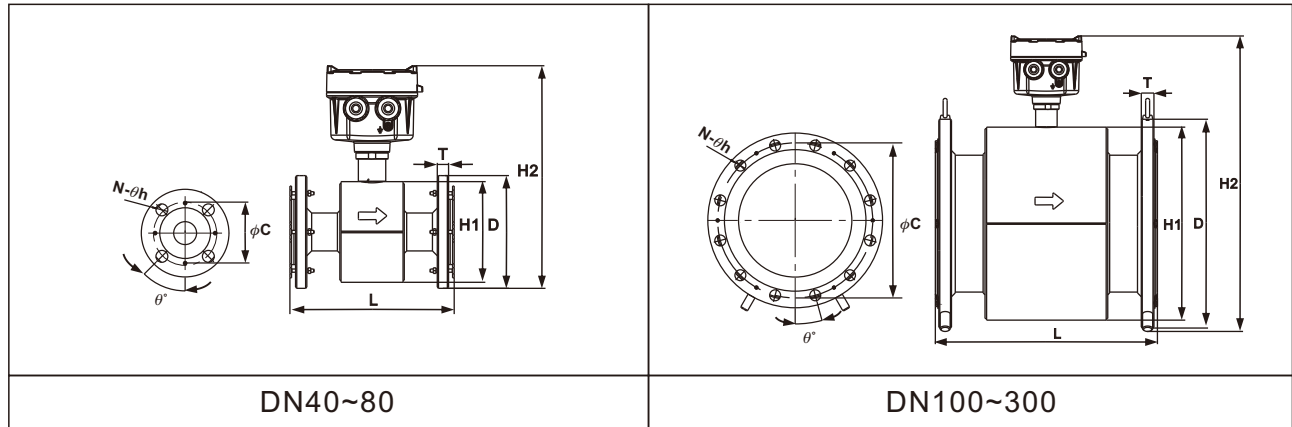

Connection specification	DIN PN40				DIN PN16						
Nominal diameter(mm)	40	50	65	80	65	80	100	125	150	200	
Lining material	PTFE										
Length	L	200	200	200	200	200	250	250	300	350	
External diameter	ϕD	150	165	185	200	185	200	220	250	285	340
PCD	ϕC	110	125	145	160	145	160	180	210	240	295
Flange thickness	t	18	20	22	24	18	20	20	22	22	24
Inclined angle of screw hole	θ°	45	45	22.5	22.5	45	22.5	22.5	22.5	22.5	15
Diameter of screw hole	θh	18	18	18	18	18	18	18	18	22	22
Quantity of screw holes	N	4	4	8	8	4	8	8	8	8	12
Height of sensor casing	H1	125	125	145	145	145	145	195	195	265	305
Total height	H2	334	341	361	369	361	369	404	419	484	524
Weight (kg)*2		5.53	6.17	7.43	10.70	7.03	10.70	14.07	19.41	26.68	38.42

Connection specification	DIN PN10			
Nominal diameter(mm)	200	250	300	
Lining material	PTFE			
Length	L	350	400	500
External diameter	ϕD	340	395	445
PCD	ϕC	295	350	400
Flange thickness	t	24	26	26
Inclined angle of screw hole	θ°	22.5	15	15
Diameter of screw hole	θh	22	22	22
Quantity of screw holes	N	8	12	12
Height of sensor casing	H1	305	365	406
Total height	H2	524	582	651
Weight (kg)*2		31.68	52.48	68

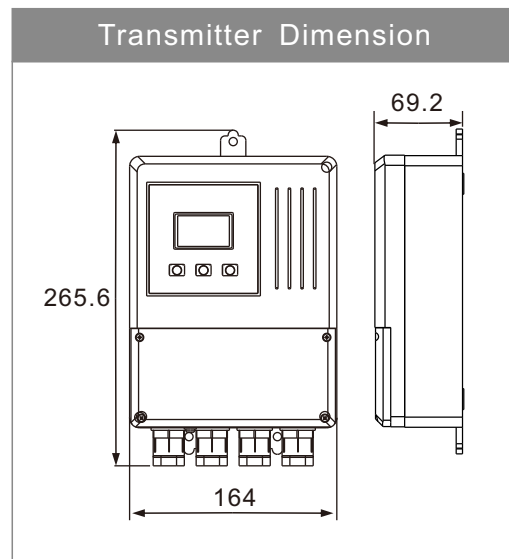

Note 1 : N40~DN80, the lining protection rings 2mm. The total flange-to-flange length of the flow meter needs to add 4mm
 Note 2 : DN100~DN300, the lining protection rings 0.5mm. The total flange-to-flange length of the flow meter needs to add 1mm

PIPE DIAMETER, FLOW RANGE AND ACCURACY SELECTION

Pipe diameter (mm)	Flow range (m ³ /h)	
	Flowing speed 0.1~1.0m/s	Flowing speed 1.0~10m/s
40	0.45~4.5	4.5~45.2
50	0.71~7.1	7.1~71
65	1.19~11.9	11.9~119
80	1.81~18.1	18.1~181
100	2.83~28.3	28.3~283
125	4.42~44.2	44.2~442
150	6.36~63.6	63.6~636
200	11.3~113	113~1130
250	17.7~177	177~1770
300	25.4~254	254~2540

Accuracy class & tolerance

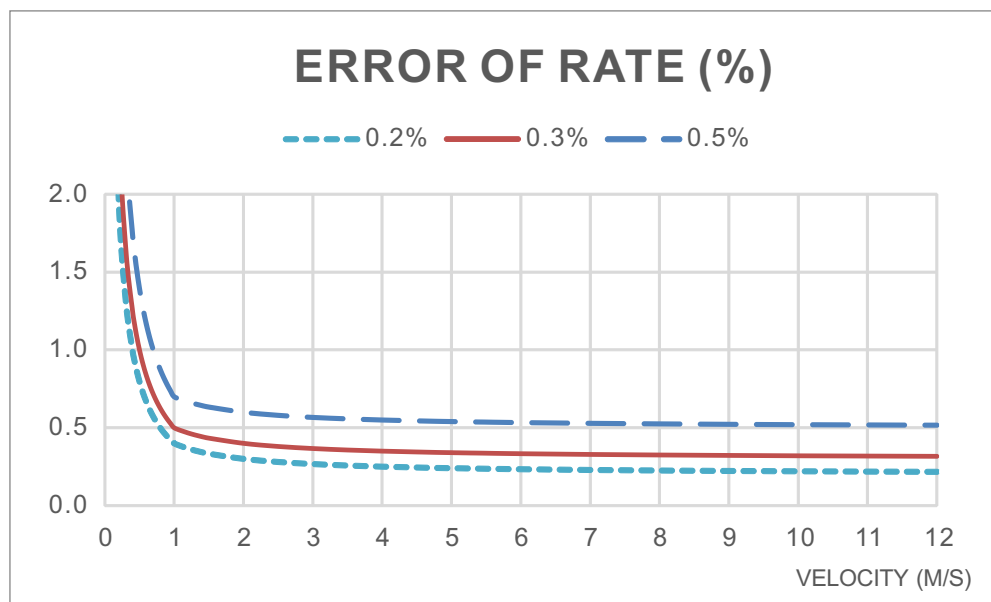

INSTALLATION INSTRUCTIONS

1. The flow meter must be free from strong electromagnetic field. The magnetic intensity of the flow meter installation site must be smaller than 400A/m (It should not be installed near large motors or transformers).
2. It should be installed at the lower point and the vertically upward point of the horizontal pipe. Don't install it at the highest point and the vertically downward point of the pipe.

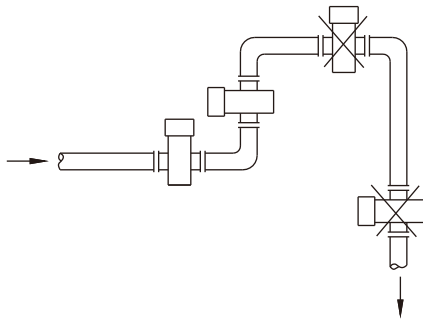

3. It should be installed at the rising point of the pipe.



4. It should be installed at the lower point of the pipe when it is installed on the pipe with opening for drainage.

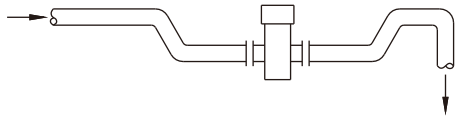

5. If the pipe gap exceeds 5m, the air release valve should be installed at the downstream of the sensor. The downstream of the sensor should have some back pressure.

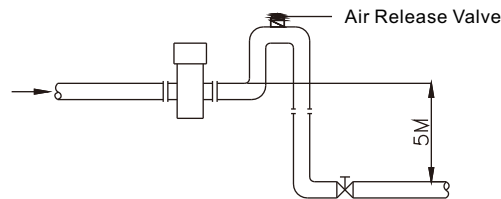

6. The control valve and cut valve should be installed at the downstream of the sensor rather than the upstream.

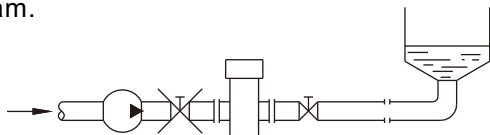

7. The sensor should be installed at the pump outlet rather than the inlet.

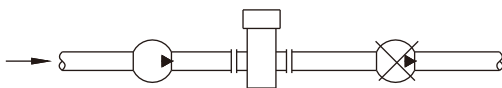

8. The fluidic must flow towards the arrow direction of the flow meter.
9. The axial line of the measuring electrode must be approximate to the horizontal direction (The angle of from the horizontal direction).
10. The measuring pipe must be completely filled with liquid.

INSTALLATION INSTRUCTIONS

11. The straight tube section is required to be at least 5D (internal diameter of the flow meter) on the front side, and at least 2D on the rear side.

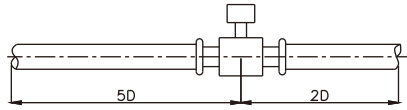

12. When measuring the mixture of different media, the distance between the mixing point and the flow meter must be 30D at least.

13. For convenient cleaning and maintenance of the flow meter, a bypass pipe must be installed.

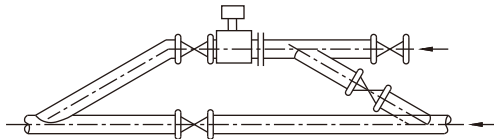

14. When installing the sensor, it should ensure that the measuring pipe and the process pipe must be on the same axial line. For the flow meter with the pipe meter of 50mm or below, the axial line deviation should not exceed 2mm. For those of DN65~DN150, the axial line deviation should not exceed 3mm. For those of \geq DN200, the axial line deviation should not exceed 4mm.

15. The shim installed between the flanges should have excellent anti-corrosion property. The shim should not intrude in the pipe, which will affect the fluidic in the pipe.

16. The sensor and transmitter should be equipped with high-quality independent grounding wire (The section area of the copper core is 1.6mm²). The grounding resistance should be $<10\Omega$. If the grounding is poor, it won't work normally. The grounding ring is needed if the pipe connecting with the sensor is insulating, and the material of the grounding ring should be the same as that of the electrode. If the test medium is abrasive, the neck grounding ring should be selected.

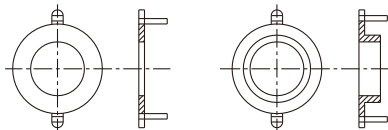

- 16.1 It is for installing the flow meter on the metal pipe not coated with insulating layer internally.

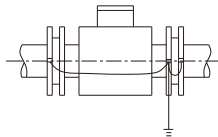

- 16.2 When installing the flow meter on the protective pipe of the cathode, the pipe with the protection of electrolytic corrosion generally has insulating walls and protruding sides. Thus, during installation, the grounding ring and the flanges on the pipe should be insulating.

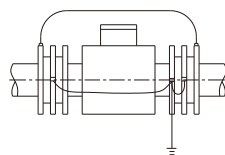

- 16.3 When installing the flow meter on the plastic pipe or the pipe with insulating coating material, paints or lining, grounding rings on both ends of the sensor should be installed.

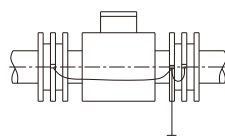

ORDERING INFORMATION

EPD 5 N J 2 0

Model _____

- 30: Standard type
- 34: Remote type¹

Pipe Diameter _____

- | | |
|------------|------------|
| 040: 40mm | 125: 125mm |
| 050: 50mm | 150: 150mm |
| 065: 65mm | 200: 200mm |
| 080: 80mm | 250: 250mm |
| 100: 100mm | 300: 300mm |

Connection Specification _____

- | | | |
|--------------------------|-----------|----------|
| V: 7.5Kg/cm ² | O: 150Lbs | W: PN10 |
| N: 10Kg/cm ² | P: 300Lbs | X : PN16 |
| F: 16Kg/cm ² | | Y : PN25 |
| G: 20Kg/cm ² | | Z : PN40 |

Casing and Flange Material _____

- 5: Carbon Steel

Lining Material _____

- H: NBR
- R: Neoprene
- E: PTFE

Electrode Material _____

- L: SUS316L
- H: Hastelloy alloy C276
- T: Titanium
- A: Tantalum

Electrode Type _____

- N: Normal Type

Power Supply and Signal Transmission _____

- J2: Integrated Flow Meter, 100~240 Vac 50/60Hz, 4-20mA, pulse output, RS-485

Accuracy _____

- F: 0.5%
- C: 0.3%
- A: 0.2%

Grounding Ring _____

- : None
- 0: SUS 304
- L: SUS316L
- H: Hastelloy alloy C276
- T: Titanium

¹ Standard cable length for EPD34 remote type is 10M; 100M is Max.

² The accuracy is 0.5% with NBR lining material

SETTING VALUES (STANDARD TYPE)

Basic Setting

No.	Parameter Option	Unit	Default	ValueRemarks
1	Device Tag Num	none	00001	
2	Zero adjustment	m/s	actual	
3	K-Factory	–	1.000	
4	Tube Size	10~100 mm	mm	actual
		125~500 mm	mm	actual
5	Flow Rate Unit	–	Liter	
6	Flow Span	–	Permitted maximum value	
7	Liquid Density	g/cm ³	1.0000	
8	Low flow Cutoff	–	0.5	
9	Flow Direction	–	Forward	
10	Total Unit	–	M ³	
11	Total Mode	–	Forward	
12	Total Reset	–	Cancel	
13	Fwd. Total Init.	–	0	
14	Rev. Total Init.	–	0	

I/O Signal Setting

No.	Parameter Option	Unit	Default	ValueRemarks
1	Damping Time	Second	1	
2	Pulse Output Mode	–	Pulse NO	
3	Pulse Output Unit	Unit/pulse	0.01 L	
4	Max. Frequency	HZ	2000	
5	Output Curr. Mode	–	4-20	
6	4mA Fine-Tune	count	0	
7	20mA Fine-Tune	count	0	
8	Digital 1 In Func	–	None	
9	Digital 1 In Type	–	NO	
10	ModBus Comm.	Modbus ID	–	1
		BaudRate	–	9600
		Data bit	bit	8
		Parity	–	none
		Stop bit	bit	1

SETTING VALUES (STANDARD TYPE)

Alarm Setting

No.	Parameter Option	Unit	Default	Value	Remarks
1	Max. Flow Rate	–	Max		
2	Min. Flow Rate	–	Min		
3	Empty Tube Detct	–	Disable		
4	Output 1 func.	–	Max Flow rate		
5	Output 1 type	–	NO		
6	Output 2 func.	–	Min Flow rate		
7	Output 2 type	–	NO		
8	Curr. Func.	–	N/A		
9	Alarm Curr. Val.	mA	NO		

SETTING VALUES (REMOTE TYPE)

Main Menu	Sub Menu	Unit	Default	Setting Range
Basic Set(1)	Device Tag Num (1.1)	none	00001	00001~65535
	Measure Type (1.2)	-	Water	Water
	Tube Size (1.3)	mm	actual	10,15,25,32,40,50,65,80,100 125,150,200,250,300,350,400,450,500
	Flow Unit (1.4)	-	m ³ /h	L/(min,h),m ³ /(min,h),gal/(min,h), kg(min,h),Ton(min,h) (Flow rate* Liquid density = weight) "L/m","L/h","m ³ /m","m ³ /h","gal/m","gal/h" ,"kg/m","kg/h","Ton/m","Ton/h","m ³ /d"
	Flow Span (1.5)	=Flow Rate Unit	(5m/s)* (Diameter/2)^2*pi* Unit of Flow Forward	(0.1 ~ 10.0m/s)* (Diameter mm/2)^2 * pi *Unit of Flow Forward
	Direction (1.6)	dir	Forward	Forward,Reverse
	Total Unit (1.7)	-	m ³	Liter,gal,m ³ ,kg,Ton
	Total Mode (1.8)	none	Forward	Forward,Reverse, Bi-direction
	Total Reset (1.9)	none	Cancel	Cancel,Accept

Main Menu	Sub Menu	Unit	Default	Setting Range
Advanced Set(2)	Zero Adj. (2.1)	m/s	actual	-0.5000~+0.5000
	K-Factor (2.2)	none	1.000	0.000~3.000
	Density (2.3)	g/cm ³	1.0000	0.0001~9.9999
	Low cutoff (2.4)	%	0.5	0.00~100.00
	Fwd. Init. (2.5)	=Total Unit	0	0~99999
	Rev. Init.(2.6)	=Total Unit	0	0~99999

Main Menu	Sub Menu	Unit	Default	Setting Range
I/O Signal Set(3)	Damping Time (3.1)	second (s)	3	0~100
	Pulse Out Mode (3.2)	none	Pulse NO	Pulse NO, Pulse NC, Frequency
	Pulse Out Unit (3.3)	Unit/pulse	0.1 L	0.001~100(L,gal,m ³ ,g,kg,Ton) m ³ /pulse,gal/pulse,m ³ /pulse g/pulse,kg/pulse,Ton/pulse
	Max. Freq. (3.4)	Hz,kHz	2K	1~8K (00.000)
	Curr. Mode (3.5)	none	4-20	4-20,0-20
	4mA Fine-Tune (3.6)	count	0	-5000~5000
	20mA Fine-Tune (3.7)	count	0	-5000~5000
	Input1 Func. (3.8)	N/A	None	None, Total Reset
	Input1 Type (3.9)	N/A	NO	NO,NC

SETTING VALUES (REMOTE TYPE)

Main Menu	Sub Menu	Unit	Default	Setting Range
Alarm Set (4)	Max. Flow (4.1)	Flow Rate Unit	Max.	Max. Flow Rate
	Min. Flow (4.2)	Flow Rate Unit	Min.	Min. Flow Rate
	Empty Tube Set (4.3)	N/A	Disable	Enable, Disable
	Output 1 Func. (4.4)	N/A	Max. Flow Rate	Max. Flow Rate, Min. Flow Rate, Empty Tube, System Alarm
	Output 1 Type (4.5)	N/A	No	NO,NC
	Output 2 Func. (4.6)	N/A	Min. Flow Rate	Max. Flow Rate, Min. Flow Rate, Empty Tube, System Alarm
	Output 2 Type (4.7)	N/A	No	NO,NC
	Curr. Func. (4.8)	N/A	None	Empty Tube, System Alarm
	Alarm Curr. (4.9)	N/A	3.6	3.6,3.8,20.5,22

APPLICATION DEMO



Pharmaceutical



Pharmacy



Beverage



Electronics

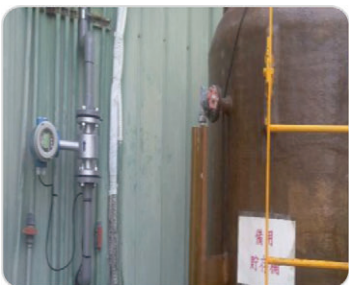

Food & Beverage



Incinerator



Mining



Plastic

TUCHENG PLANT/YILAN PLANT



EPD APPLICATION / ORDER FORM

Company Profile

Company Name: _____ Contact Person: _____

E-mail: _____ Phone: _____ Tax: _____

Application

Medium: _____ Temperature: _____ Sanitary Degree Request: Yes NO

Conductivity: _____ Viscosity: _____

Diameter of Tube (DN) : _____ Accuracy Request(%): _____ Ambient Temp.: _____

Normal Flow Rate(m³/h): _____ Max. Flow Rate(m³/h): _____ Min. Flow Rate(m³/h): _____

Connection Spec: _____ Connection Material** : _____

Pressure(Kg/m³): _____ Max. Static Pressure(Kg/m³): _____ **SUS304, SUS316, SUS316L

Lining Material* : _____ Electrode Material***: _____

* PTFE · NBR · Neoprene

***SUS316 · Hastelloy Alloy · Titanium · Tantalum

Power: 110Vac 220Vac 24Vdc

Output: 4-20mA/Pulse(freq) RS-485/Modbus

Grounding: NO YES

Installation Direction: Horizontal Vertical

Vibration Inside Tube: NO YES

Strong Magnetic Nearby: NO YES

Explosion Proof: NO YES

Explosion Proof Code: _____

Global Network

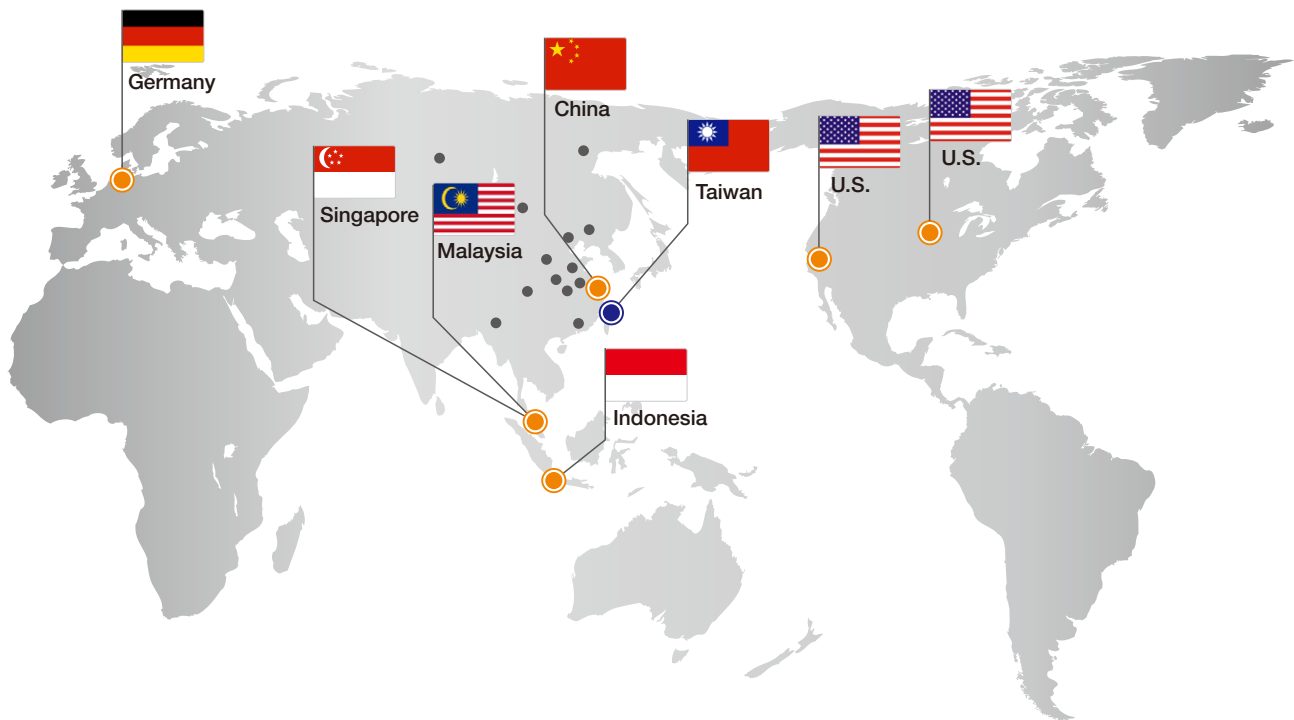

■ Asia

● Taiwan

FineTek Co., Ltd. - Taipei Head Quarter
 No.16, Tzuchiang St., Tucheng Industrial Park
 New Taipei City 236, Taiwan
 TEL: 886-2-2269-6789
 FAX: 886-2-2268-6682
 EMAIL: info@fine-tek.com

● China

Fine automation Co., Ltd. - Shanghai Factory
 No.451 DuHui Rd, MinHang District, Shanghai,
 China 201109
 TEL: 86-21-6490-7260
 EMAIL: info.sh@fine-tek.com

● Singapore

FineTek Pte Ltd. - Singapore Office
 No. 60 Kaki Bukit Place, #07-06 Eunos
 Techpark 2 Lobby B, Singapore 415979
 TEL: 65-6452-6340
 EMAIL: info.sg@fine-tek.com

● Indonesia

FineTek Co., Ltd. - Indonesia Office
 Ruko Golden 8 Blok H No.40
 Gading Serpong, Tangerang, Indonesia
 TEL: 62 (021)-2923-1688
 EMAIL: info.id@fine-tek.com

● Malaysia

FineTek Co., Ltd. - Malaysia Office
 8-05, Plaza Azalea, Persiaran Bandaraya,
 Seksyen 14, 40000 Shah Alam, Selangor, Malaysia
 TEL: 603-5524-7168
 EMAIL: info.my@fine-tek.com

■ North America

● California, U.S.

Aplus Finetek Sensor Inc. - US Office
 355 S. Lemon Ave, Suite D, Walnut,
 CA 91789
 TEL: 1 909 598 2488
 FAX: 1 909 598 3188
 EMAIL: info@aplusfine.com

● Illinois, U.S.

Aplus Finetek Sensor Inc.
 TEL: 1 815 632-3132
 FAX: 1 815 716 8464
 EMAIL: info@aplusfine.com

■ Europe

● Germany

FineTeK GmbH - Germany Office
 Frankfurter Str. 62, OG D-65428
 Ruesselsheim, Germany
 TEL: +49-(0)6142-17608-0
 FAX: +49-(0)6142-17608-20
 EMAIL: info@fine-tek.de



Distributor: